



## SEPARATORS

DN15-200 (½" – 8") PN16 Carbon Steel

**Fig. SP316**

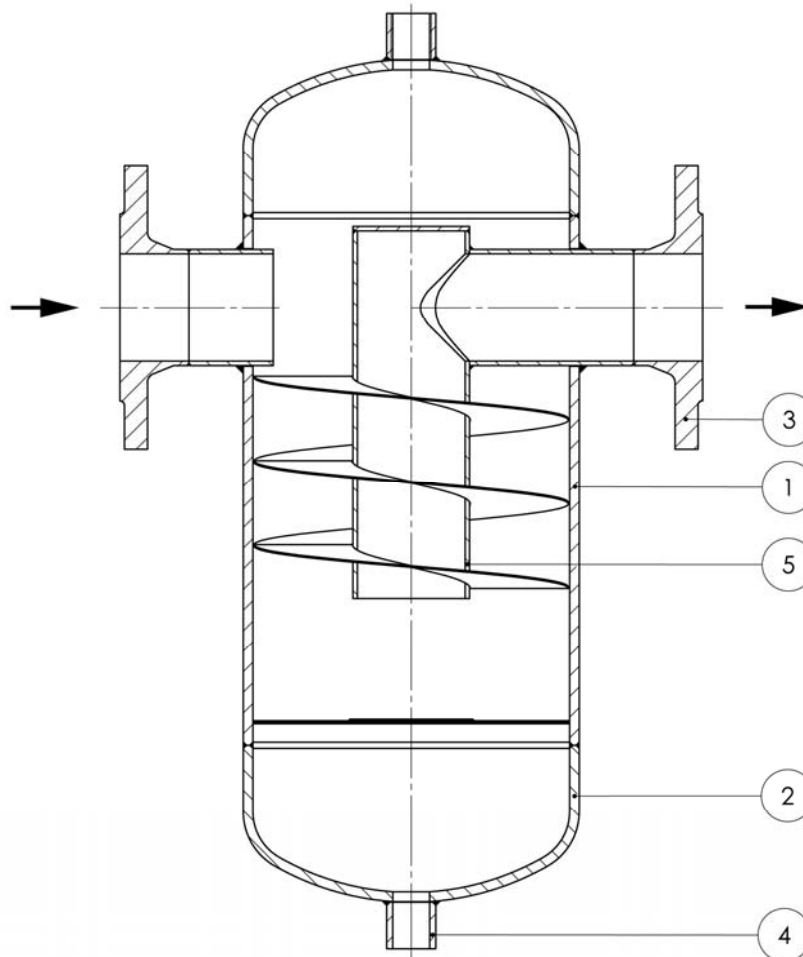

AJ VALVELINE. S.L.  
e-mail: [ajvalveline@ajvalveline.com](mailto:ajvalveline@ajvalveline.com)  
[www.ajvalveline.com](http://www.ajvalveline.com)

**Parts and materials**

Item	Description	Material
1	Body	A106 Gr. B / A516 Gr.70
2	Heads	A234 WPB / A516 Gr. 70
3	Inlet / Outlet flanges	A105 / S235JR
4	Sockets	ASTM A105
5	Internals	A106 Gr. B / A516 Gr. 70

(\*) Other materials under request.



Dimensions

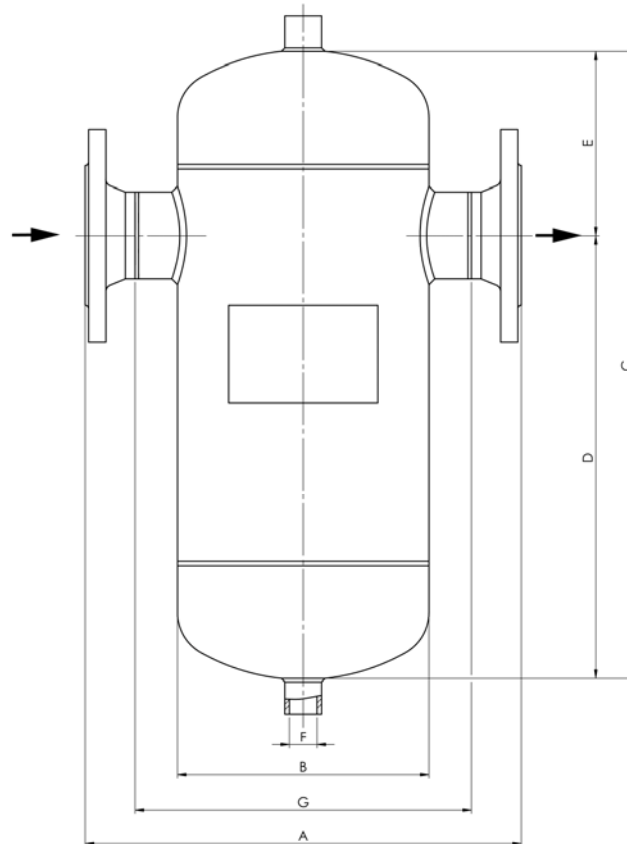

SIZE	PN 16 FLANGES							SCREWED ENDS		
	A	B	C	D	E	F	VOL dm <sup>3</sup>	WEIGHT	G	WEIGHT
15 (½")	230	114	260	176	84	½"	2	7,5	160	6,20
20 (¾")	230	114	260	171	89	½"	2,5	8	154	6,10
25 (1")	230	114	300	211	89	½"	3	8,5	154	6,22
32 (1 ¼")	260	140	395	279	116	½"	5	12	180	8,62
40 (½")	260	140	435	335	100	½"	5,7	13,8	176	10,08
50 (2")	310	168	505	366	139	½"	10,5	19,5	220	14,44
65 (2 ½")	380	219	550	388	162	¾"	18,5	32	290	25,88
80 (3")	400	219	620	456	164	¾"	25	37,7	300	30,30
100 (4")	485	273	715	504	211	¾"	35,4	57	381	47,76
125 (5")	555	324	845	595	250	1"	50	81,5	445	68,90
150 (6")	585	356	1072	626	446	1"	75	157	475	141,50
200 (8")	700	457	1210	879	331	1"	95	242	576	220,00

(\* ) Dimensions in mm and weight in kg.

AJ VALVELINE. S.L.  
 e-mail: [ajvalveline@ajvalveline.com](mailto:ajvalveline@ajvalveline.com)  
[www.ajvalveline.com](http://www.ajvalveline.com)



Application limits, CE Marking, Category & Limiting conditions

Application limits / CE Marking

SIZE	DN15	DN20	DN25	DN32	DN40	DN50	DN65	DN80	DN100	DN125	DN150	DN200
RATING	PN16	PN16	PN16	PN16	PN16	PN16	PN16	PN16	PN16	PN16	PN16	PN16
CATEGORY	SEP	SEP	SEP	SEP	SEP	SEP	SEP	SEP	SEP	1	1	1
RATING	PN40	PN40	PN40	PN40	PN40	PN40	PN40	PN40	PN40	PN40	PN40	PN25
CATEGORY	SEP	SEP	SEP	SEP	SEP	1	1	1	1	1	1	1

Group 2 Gases Categories

RATING	SIZES DN	CATEGORY
DIN PN16	15-100	SEP
DIN PN16	125-200	1
DIN PN25	200	1
DIN PN40	15-40	SEP
DIN PN40	50-150	1

CE Marking:

This product have been designed for use on water, steam, air and other gases wich are in Group 2 of the PED European Pressure Equipment Directive 97/23EC and it comply with those requirements.

This product carry the CE mark when falling in category 1 and above.

Limiting conditions

	PRESS. Bar	TEMP °C
DIN PN16	13,4	20
	11(1)	188
	11,5	250
ANSI 150# Flanges	16,8	20
	14(1)	198
DIN PN25	21	20
	17	207
	15,9	300
DIN PN40	33,6	20
	27(1)	230
	25,5	300

(1) Maximum operation pressure for saturated steam.

Minimum operation temperature: -10°C

Design code: AD-Merkblatt (2000)